

Model PM5000 Portable Milling Machine

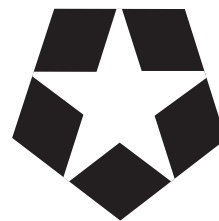

- Features
- Applications
- Setup & Operation
- Components & Accessories
- Technical Data



CLIMAX

Portable Machine Tools, Inc.

Portable on-site

milling solves your difficult repair problems

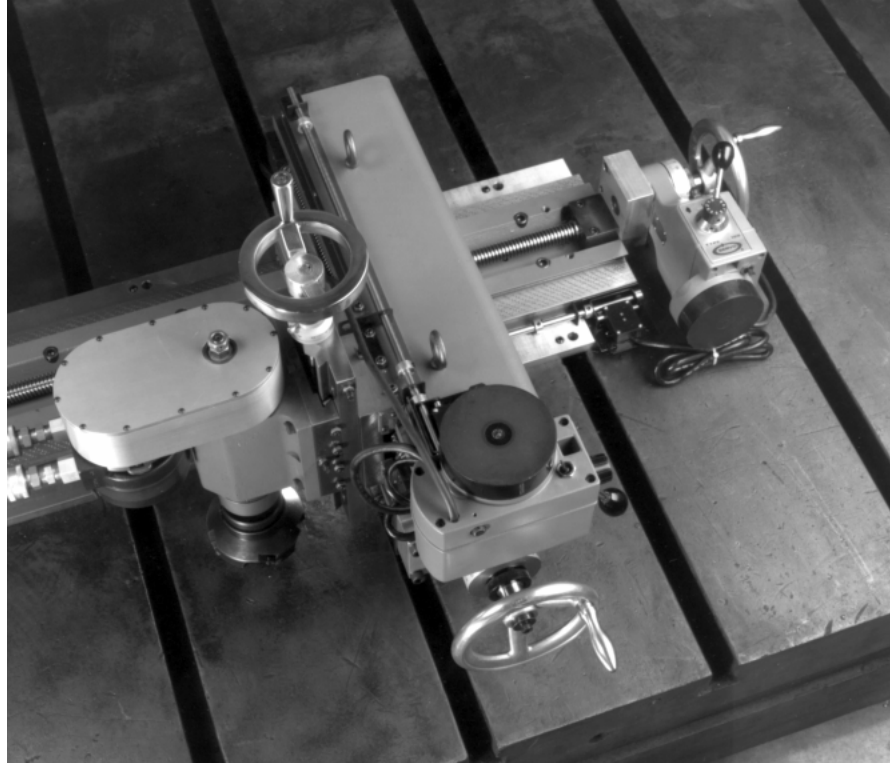

The Model PM5000 Portable Milling Machine

The versatile PM5000 three-axis hydraulic milling machine consists of a 12" (305 mm) wide bed with an 8" (203 mm) wide saddle. A 22" (559 mm) long cross carriage ram provides 14" (356 mm) travel and can be centered across the bed, extended over either side of the bed, or positioned parallel to the bed. The bed's dovetail ways feature a high-lubricity polymer for smooth operation.

The milling head is belt driven. A drawbolt holds the machine tool in the spindle. The spindle has a 3" (76.2 mm) diameter hard chrome-plated quill and hardened helical drive gears. The spindle gear box rotates around the spindle centerline. The heavy-duty quill clamp can be indexed in 90° increments and offset mounted to increase

machining reach. Spindle travel is provided by a 6" (152 mm) dovetail slide with manual feed. Tools attach by a #40 machine tool taper with drawbolt retention. Power feeds are available for the X and Y axes.

Standard or heavy-duty power feeds are available. The standard feed can be used in normal horizontal milling applications. Vertical or overhead milling requires the heavy-duty power feed. Combine this unit with remote pendant controls and mount it in various positions on the end of the bed or cross carriage to avoid obstructions. Three hydraulic spindle motors are available so you can match the spindle rpm range to your application. Five and ten hp hydraulic power units are available.

Applications

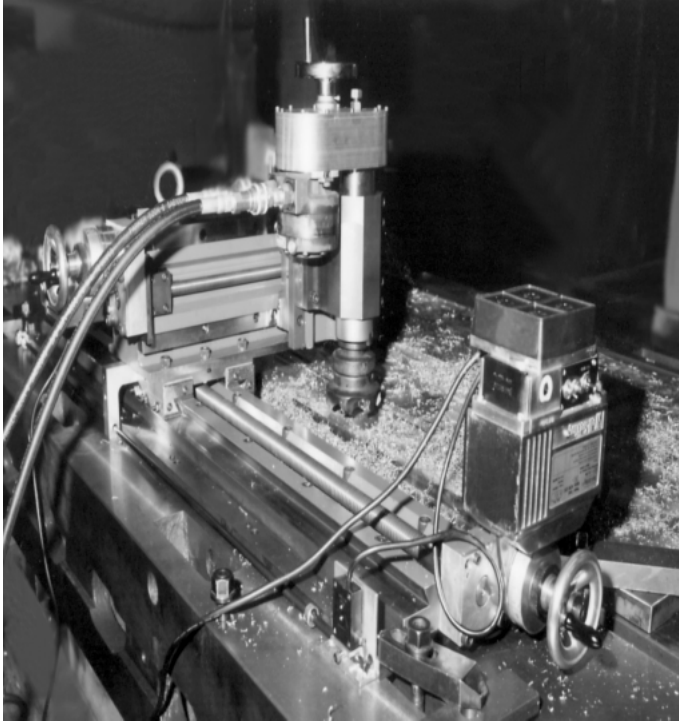

Press Platens

Versatile spindle positioning makes the Model PM5000 ideal for machining damaged areas on the platens of large presses, hammers, and injection molding machines.

Weldment Milling

Fabrications often need to have weldments milled flush to establish true equipment mounting surfaces. The Model PM5000 is quick to set up for milling long straight surfaces.

Mounting Pad Milling

During construction or retrofit, use the PM5000 to mill the surface of pads for mounting winches, cranes, pumps, compressors, and turbines.

Power Generation

When motors mounted on steel pads embedded in concrete go out of alignment, the motor mount can be re-machined in-place using a Model PM5000. Repair horizontal joints on turbines and pumps too.

Model PM5000 Setup & Operation

Versatile setup...even for overhead machining.

Setup of the Model PM5000 Portable Mill consists of positioning it where you want it in relation to the work piece and clamping or bolting it securely in place. Mounting rigidity is very important to any successful milling operation with a portable milling machine. The best way to mount the machine is to weld attachment points right on the piece to be machined. This ties the machine to the work piece and eliminates vibration, flexing and other sources of chatter. If you are using an overhead frame for mounting the machine upside down, be sure it is rigid

enough to handle the weight of the machine and the side forces that occur during milling operations. Jacking screws adjust the PM5000 for accurate machining.

Milling overhead press frames and platens or other similar applications is easy with the Model PM5000 mill. It takes about five minutes to remove the spindle, reposition the quill housing and replace the spindle. To avoid obstructions, the gear box can be rotated 180°. The power feeds can also be mounted on either end of the cross carriage ram and the bed. Offset the cross carriage ram over the bed to extend or decrease tool head reach.

Components & Accessories

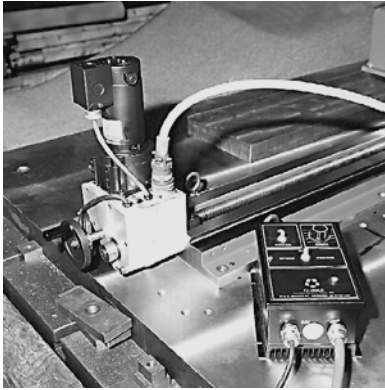

Power Feeds

Three types of power feed units are available with the Model PM5000 Portable Mill. The standard feed unit with 1/8 hp electric motor has feed speed and direction controls right on the feed unit itself. While adequate for horizontal milling, these units are not recommended for vertical milling.

The heavy-duty feed units with 1/8 hp electric motors have local controls. These units provide the power necessary for vertical milling. Either type of feed unit has three mounting positions.



Hydraulic Power Units

Several 5 hp/6 gpm (3.73 kW/22.7 liter/min) variable displacement piston pump hydraulic power units with various electrical configurations are available.

Riser Blocks (not shown)

Vertical reach can be increased by inserting a riser block between the bed saddle and the cross carriage ram. One-inch to six-inch (25.4 mm to 152.4 mm) thick blocks are available. A riser is required if the machine is used for overhead milling.

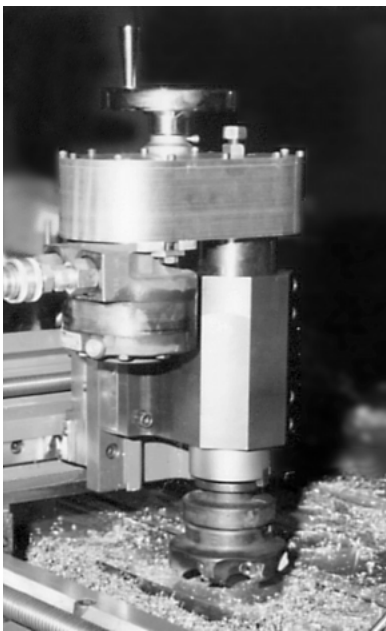

Spindle Drive Motors

Spindle speed range is determined by the hydraulic motor that is used. A wide range of speeds is available with a series of hydraulic motors.

PM5000 Specifications

Inch (mm) For precise dimensions consult your factory representative.

(A) MAIN BED:

Height (w/saddle)	4.96	(126.0)
Width	12.0	(304.8)
Length (varies)	58.0	(1473.2)
	82.0	(2082.8)
	106.0	(2692.4)

MAIN BED SADDLE:

Mounting face	8 x 8	(203.2 x 203.2)
Travel (varies)	48	(1219.2)
	72	(1828.8)
	96	(2438.4)

(B) RAM & CROSS SLIDE:

Height (w/saddle)	7.62	(193.5)
Width (w/saddle)	8.92	(226.6)
Length	22.0	(558.8)
Cross slide mounting face	6 x 6	(152.4 x 152.4)
Cross slide travel	14.0	(355.6)
Indexable, 90° increments. Can be offset in 3.38" (85.85) increments.		

(C) VERTICAL SLIDE:

Height	2.0	(50.8)
Width	6.0	(152.4)
Length	12.0	(304.8)
Mounting face	6 x 6	(152.4x152.4)
Travel	6.0	(152.4)

(D) FEED ASSEMBLIES:

Feed assemblies are required for both X and Y axes.

MANUAL FEED: .20"/rev (5.08 mm/rev)

STANDARD ELECTRIC FEED, 115v:

Manual feed (handwheel) .10"/rev (2.54 mm/rev)
Electric feed 0-10"/min (0-254 mm/min)

HEAVY-DUTY ELECTRIC FEED, 115v:

Manual feed (handwheel) .10"/rev (2.54 mm/rev)
Electric feed 0-24"/min (0-609.6 mm/min)

(F) MILLING HEAD ASSEMBLY:

SPINDLE:

Quill diameter 3 (76.2)
Tool sizes available #40 taper

QUILL CLAMP: Indexable, 90° increments.

MILLING HEAD GEAR BOX:

Drive ratio (belt drive) 1:1
Hydraulic rpm varies by motor selected (see pg. 13)

Milling head gear box can be rotated around spindle centerline 180°.

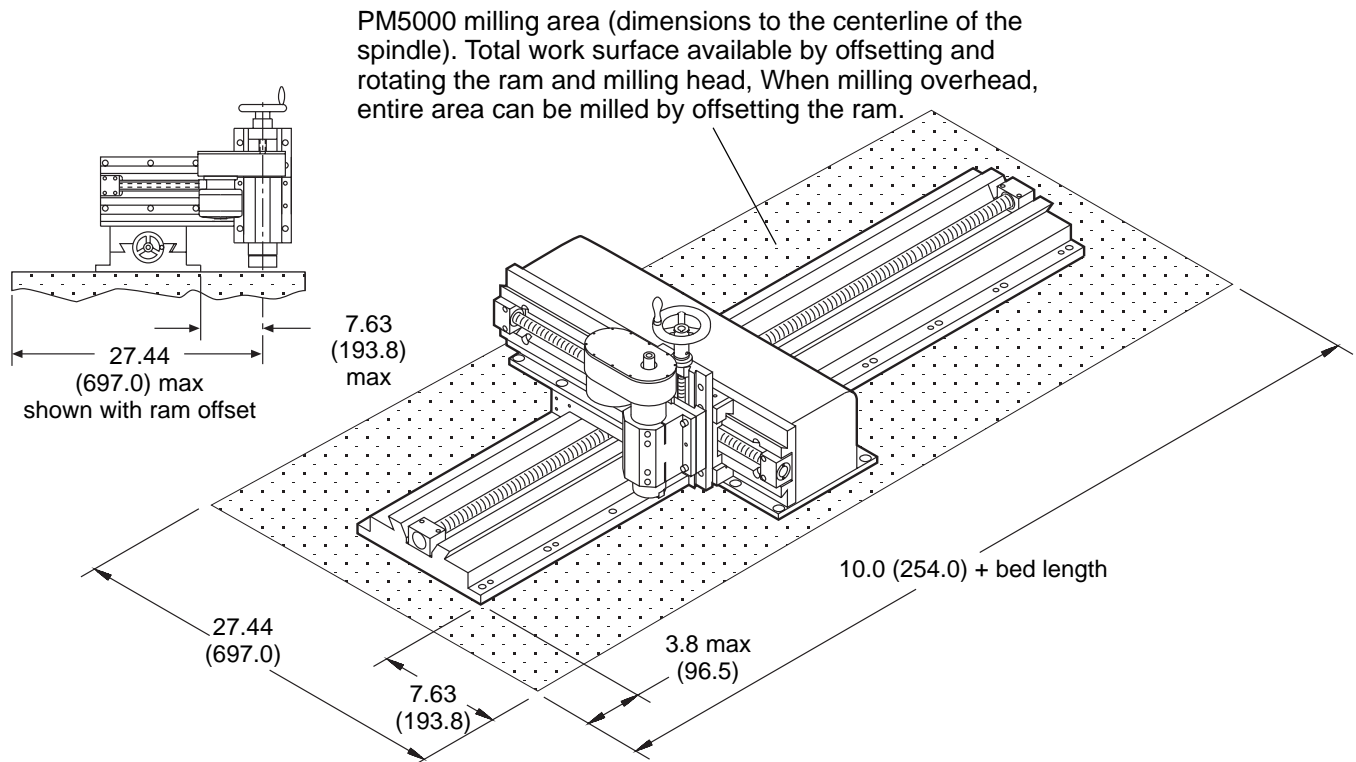

PM5000 Operational Dimensions

Inches (mm)

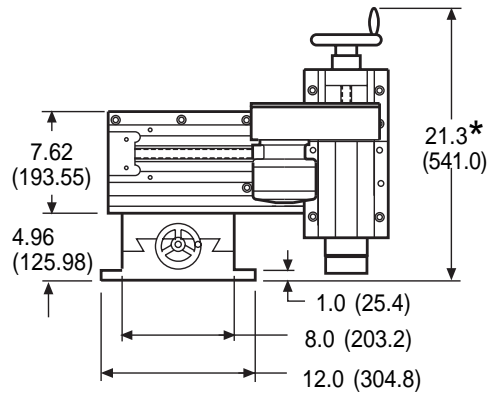
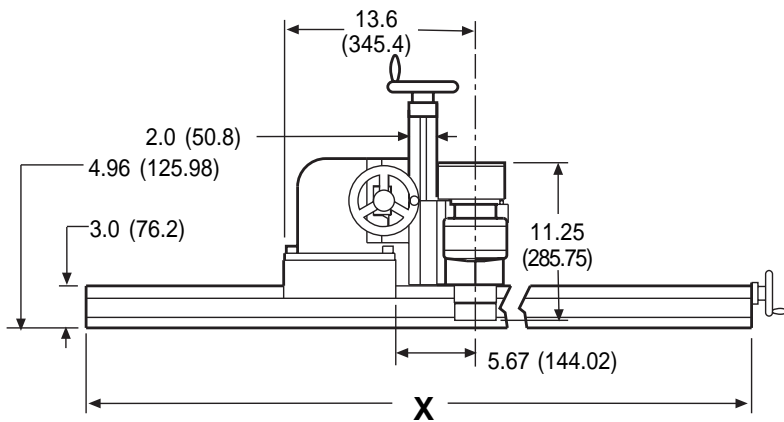
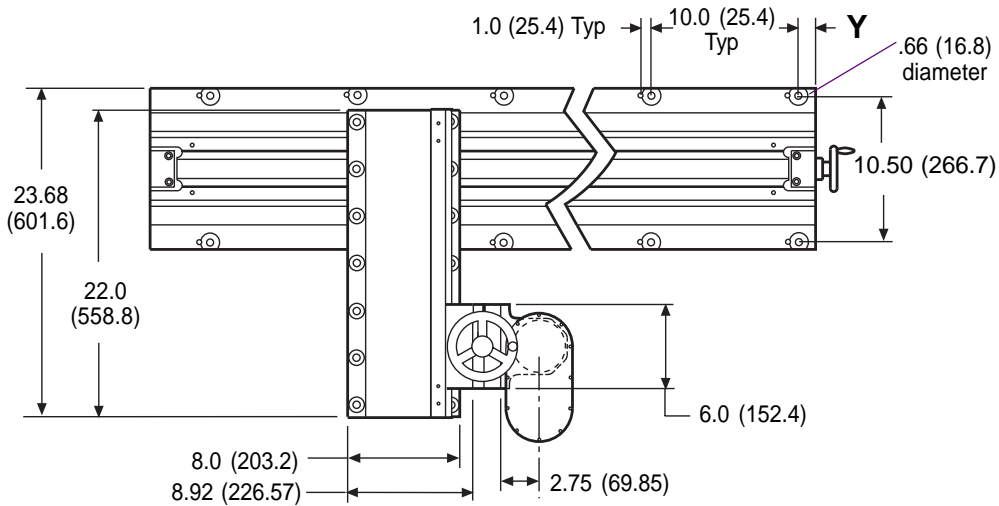

* When the vertical slide is mounted in the center position, the milling head can be positioned up or down 2.12 (53.8).

	48 (1219.2) Travel	72 (1828.8) Travel	96 (2438.4) Travel
X	58.0 (1473.2)	82.0 (2082.8)	106.0 (2692.4)
Y	4.0 (101.6)	1.0 (25.4)	3.0 (76.2)

MAIN BED ASSEMBLY

Model PM5000 Test Data

MACHINE ACCURACY Inches (mm)

Parameters:

- 5 hp 6 gpm (3.73 kW, 22.7 L/min) hydraulic power unit.
- Mist coolant.
- Recommended milling cutter with sharp milling inserts (see chart below).
- A-36 steel plate.
- Skilled operator.
- Accurate alignment equipment (laser, optics, etc.)
- Machine components trammed.
- Bed fully supported.
- Milling completed in one setup with machine in horizontal position.

Results:

- .004 (.102) flatness over 9 x 48 (228.6 x 1219.2) area (ram on one side of the bed) (A-36 steel plate).
- .006 (.152) flatness over 9 x 48 (228.6 x 1219.2) area on each side of bed (ram moved straight across to opposite side of bed) (A-36 steel plate). Improved accuracies may be obtained by resetting the Z-axis and re-tramming the milling head.

Metal Removal Rates:

- 1.5 - 2.0 in³/min (24.6 - 32.8 cm³/min) continuous, 2.5 in³/min (41.0 cm³/min) intermittent in A-36 steel plate with **5 hp** (3.73 kW) 6 gpm (22.7 L/min) hydraulic power unit.

	Test #1	Test #2	Test #3	Test #4	Test #5
Hydraulic power unit size	5 hp 6 gpm (3.73 kW 22.7 L/min.)				
Motor size	3.6 in ³ /rev (59.0 cm ³ /rev)			5.9 in ³ /rev (96.8 cm ³ /rev)	
Machine orientation	Horizontal				Vertical
Work piece material	A-36 steel				
Milling cutter	4 (102) diameter*			3/4 (20) dia. 2-flute end mill	2-1/2 (64) 6 inserts
Inserts	Mitsubishi SEEN42AFTNI F620				
Spindle RPM	375 rpm			255 rpm	231 rpm
Cutting depth	.058 (1.47)	.057 (1.45)	.042 (1.07)	.560 (14.2)	.040 (1.02)
Feed rate	7 in/min (177.8 mm/min)	11 in/min (279.4 mm/min)	16 in/min (406.4 mm/min)	1.25 in/min (31.8 mm/min)	8.6 in/min (218.4 mm/min)
Coolant	Yes	No	Yes		
Metal removal rate	1.6 in ³ /min (26.2 cm ³ /min)	2.5 in ³ /min (41.0 cm ³ /min)	2.7 in ³ /min (44.3 cm ³ /min)	0.53 in ³ /min (8.7 cm ³ /min)	0.86 in ³ /min (14.1 cm ³ /min)
Surface finish	Ra 100	Ra 250		Ra 125	

(* Recommended face mills:

1. Mitsubishi SE445RO405E, 4" diameter, 5 teeth, 45° lead angle, +19° axial rake, -2° radial rake, +13° cutting rake.

2. Seco/Carboloy R220. 13-04.00-12, 4" diameter, 6 teeth, 45° lead angle, +20° axial rake, -3° radial rake, +12° cutting rake.

PM5000 Orientation Options

MULTIPLE RAM POSITIONS

The cross slide ram can be repositioned and indexed in 90° increments for maximum versatility. For maximum accuracy, re-tram the milling head and reset after repositioning any components.

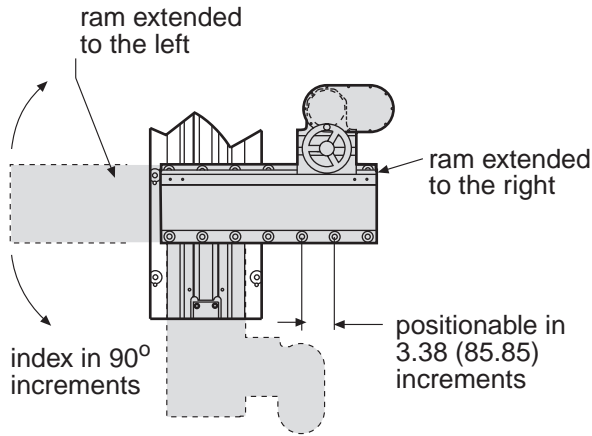

Inches (mm)

GEAR BOX POSITIONS

The lightweight aluminum gear box can be rotated around the spindle centerline 180° to clear obstructions.

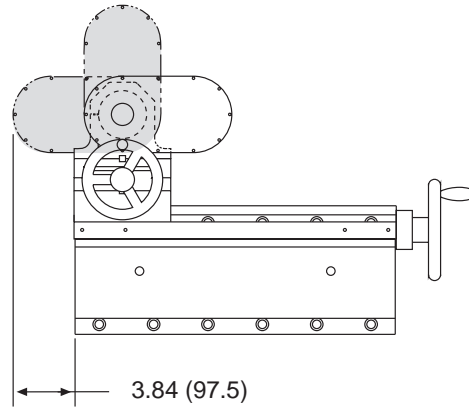

MILLING HEAD POSITIONS

Because the quill clamp is symmetrical, the milling head can be indexed in 90° increments around the vertical slide on the ram. This allows the milling head to

machine down, overhead, or to the side. The milling head can also be offset to increase tool reach. For maximum accuracy, re-tram and reset the milling head after repositioning any components.

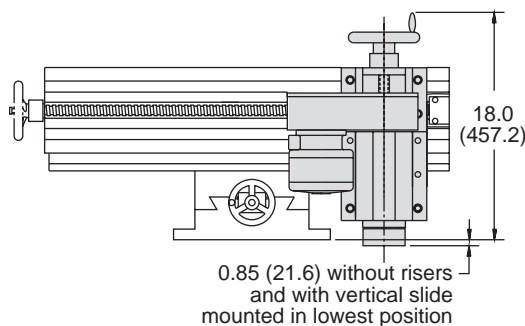
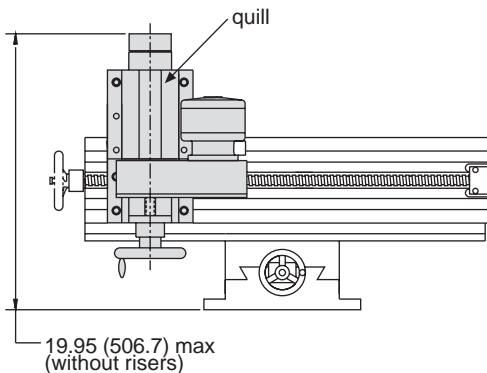
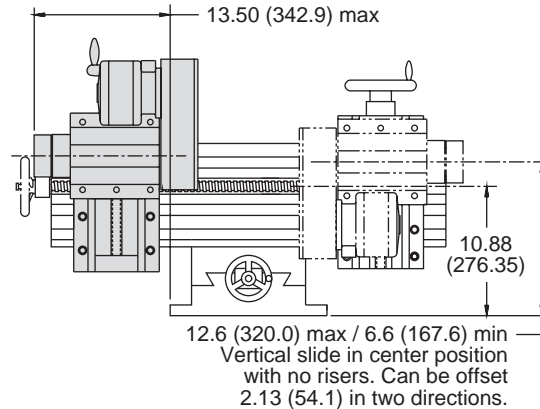
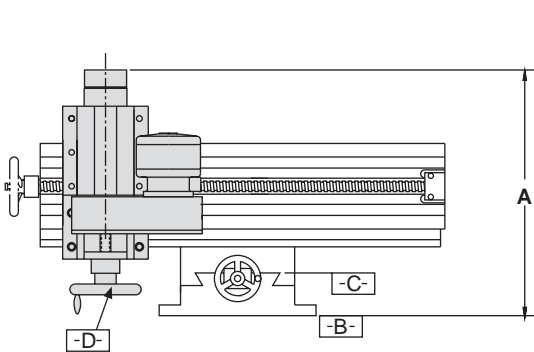

Minimum "A"	With handwheel -D-	Without handwheel -D-
Required to clear -B-	17.8 (452.2) w/o riser	15.6 (396.3) w/o riser
Required to clear -C-	20.8 (528.4) with 3 (76.2) riser	17.8 (452.2) w/o riser

PM5000 Feed Assemblies

Inches (mm)

Feed units available:

- Manual
- Standard electric with local control
- Heavy-duty electric with local control
- Heavy-duty electric with remote control

Manual and electric feed units are available for X and Y axes. The Z-axis comes complete with manual feed (electric feed is not available).

MANUAL FEED

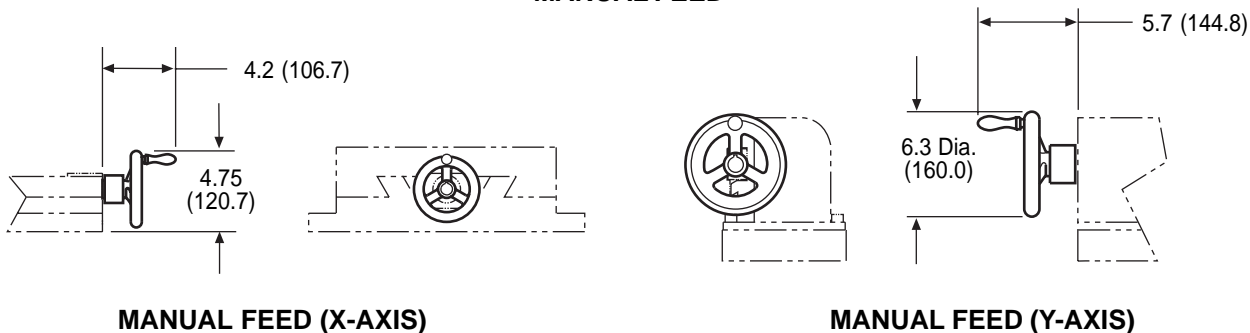

MANUAL FEED (X-AXIS)

MANUAL FEED (Y-AXIS)

STANDARD ELECTRIC FEED

(Includes limit switches)

Standard feed system recommended for horizontal applications only. For vertical or overhead applications use the heavy-duty feed system.

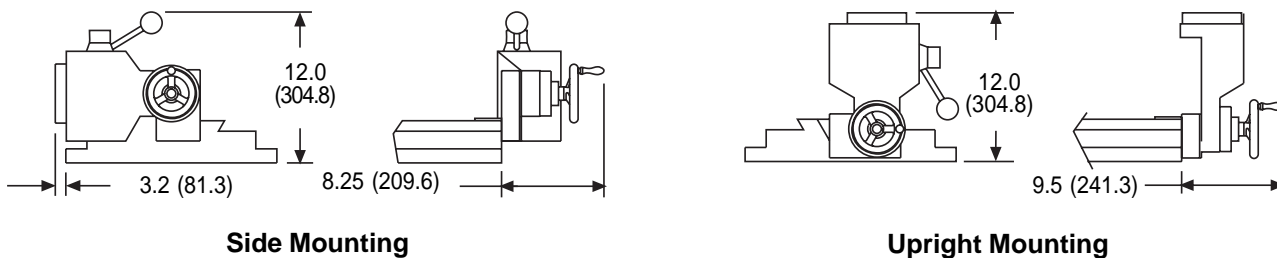

Side Mounting

Upright Mounting

HEAVY-DUTY ELECTRIC FEED

(Includes limit switches)

Recommended for vertical or overhead applications

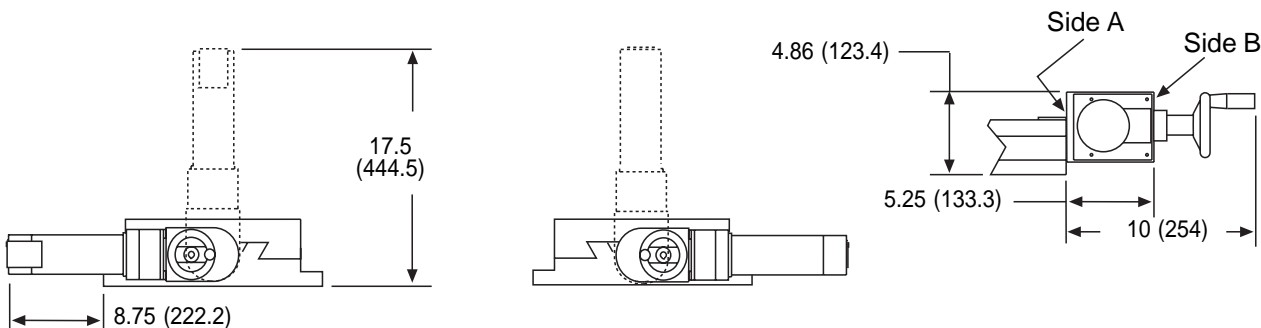

Side A mounted to bed (multiple feed positions shown)

Rotated gear box Side B mounted to bed with handwheel repositioned (multiple feed motor positions shown)

PM5000 Components

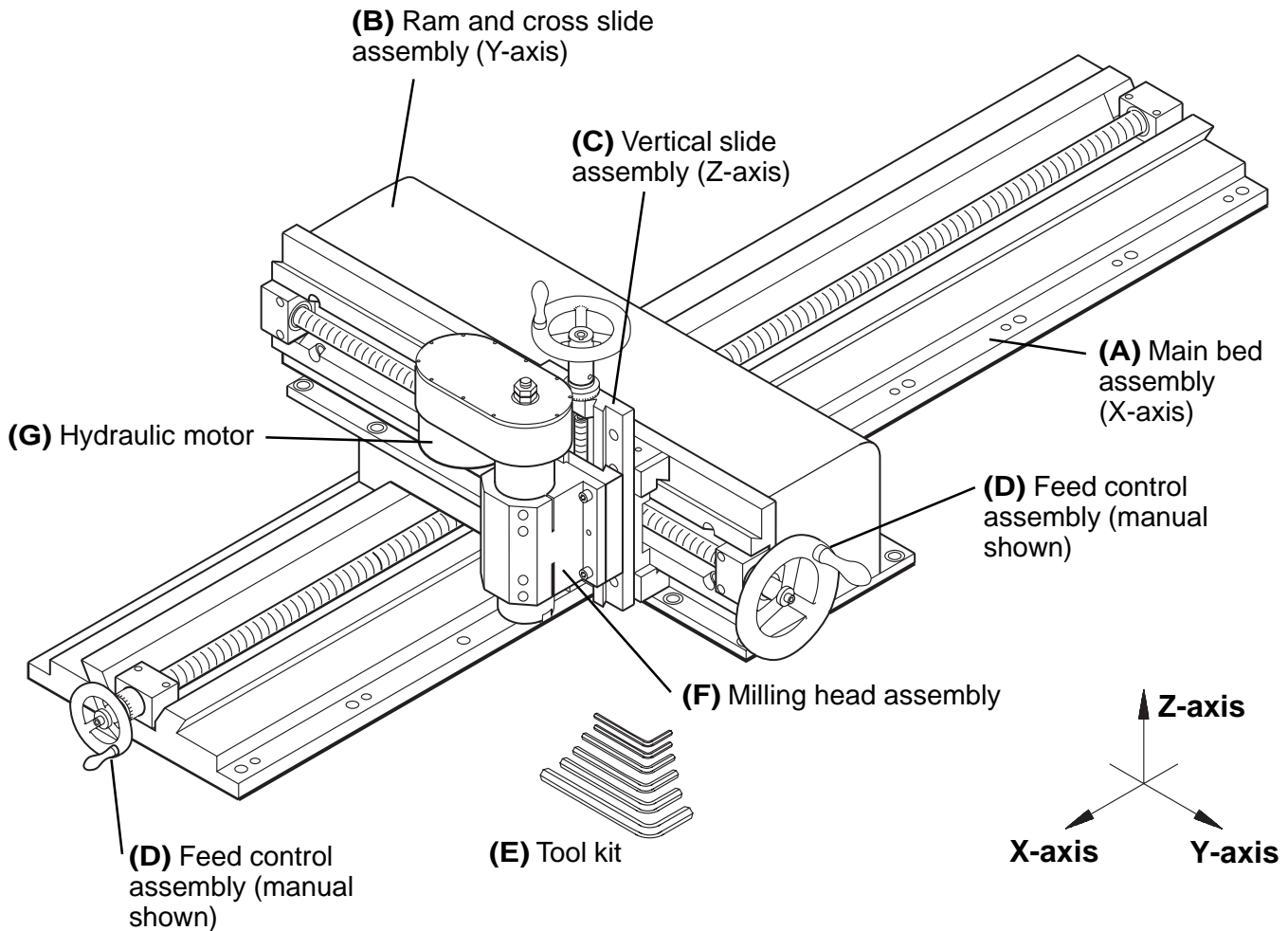

To accommodate a wide range of applications, the Model PM5000 Portable Mill is ordered as a combination of components. To order a complete machine you must specify the following:

- (A) Main bed assembly (X-axis)
- (B) Ram and cross slide assembly (Y-axis)
- (C) Vertical slide assembly (Z-axis)
- (D) Feed control assembly (manual or electric) for X and Y axes (electric assemblies include limit switches)
- (E) Tool kit
- (F) Milling head assembly
- (G) Hydraulic motor
- (H) Hydraulic power unit (not shown)
- (I) Optional riser assembly (not shown)

The Model PM5000 is a made-to-order machine. Expect longer lead times when ordering.

PM5000 Work Sheet

Inch (mm) NOTE: Contact your factory representative for additional information and lead times.

Component	Part Number
(A) Main bed assembly (X-axis):	
48" (1219.2) travel	27218 _____
72" (1828.8) travel	27219 _____
96" (2438.4) travel	27220 _____

(D_x) Main bed feed control assembly:	
Standard electric (includes limit switch assembly):	
48" (1219.2) bed	21786 _____
72" (1828.8) bed	21509 _____
96" (3048.0) bed	22747 _____

Recommended for horizontal applications only. For vertical applications use heavy-duty feed system.

OR	
Heavy-duty electric - local control (includes limit switch assembly):	
48" (1219.2) bed	29619 _____
72" (1828.8) bed	29621 _____
96" (3048.0) bed	29615 _____

Recommended for vertical or overhead applications.

OR	
Manual feed:	20808 _____

(B) Ram and cross slide assembly (Y-axis):	
14" (355.6) travel	22643 _____

(D_y) Ram feed control assembly:	
Standard electric - local control (includes limit switch assembly):	21512 _____

OR	
Heavy-duty electric (includes limit switch assembly):	29617 _____

OR	
Manual feed:	23650 _____

(C) Vertical slide assembly (Z-axis):	
(includes manual feed handwheel)	
6" (152.4 mm travel)	20888 _____

(D) Feed assembly - see assembly to be controlled for available feeds.

Component	Part Number
(E) Tool kit:	20997 _____

(F) Milling head assembly	
#40 Taper	20667 _____

(G) Hydraulic motor:	
3.6 in ³ (59.0 cm ³)	20684 _____
5.9 in ³ (96.8 cm ³)	21530 _____
7.3 in ³ (119.7 cm ³)	20231 _____
Hydraulic fitting kit	25492 _____

(H) Hydraulic power unit - 5 hp:	
3-Phase/230V/60 Hz	25318 _____
3-Phase/460V/60 Hz	25319 _____
3-Phase/550V/50 Hz	25320 _____
3-Phase/575V/60 Hz	25321 _____
1-Phase/230V/60 Hz	25322 _____
1-Phase/220V/50 Hz	25323 _____
3-Phase/440V/50 Hz	24592 _____
3-Phase/220V/50 Hz	24593 _____
3-Phase/380V/50 Hz	24594 _____
3-Phase/200V/50 Hz	24595 _____

(H) Hydraulic power unit - 5 hp economy:	
3-Phase /230V/60 Hz	31525 _____
3-Phase/460V/60 Hz	31526 _____
1-phase/230V/60 Hz	31527 _____
3-Phase/380V/50 Hz	31528 _____
3-Phase/440V/50 Hz	31529 _____
3-Phase/550V/50 Hz	31530 _____

Remote spindle speed pendant for electric power unit (optional): -1 _____

(I) Riser/stud assembly (optional):	
1" (25.4 mm) riser	25021 _____
2" (50.8 mm) riser	21593 _____
3" (76.2 mm) riser	25022 _____
4" (101.6 mm) riser	25023 _____
5" (127.0 mm) riser	25024 _____
6" (152.4 mm) riser	25025 _____

Studs (optional/four required):	
1" (25.4 mm) riser height	25030 _____
2" (50.8 mm) riser height	21595 _____
3" (76.2 mm) riser height	25031 _____
4" (101.6 mm) riser height	25032 _____
5" (127.0 mm) riser height	25033 _____
6" (152.4 mm) riser height	25034 _____
7" (177.8 mm) riser height	25040 _____

PM5000 Components

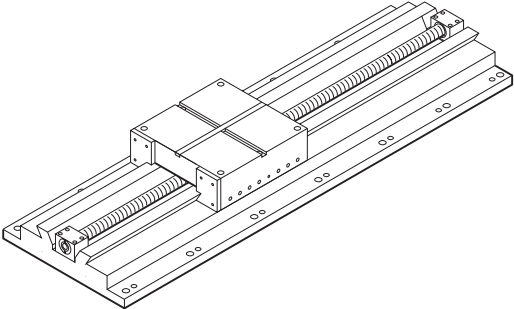
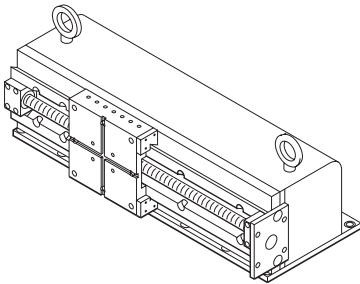
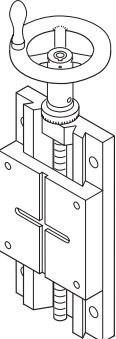
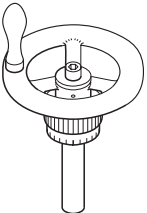
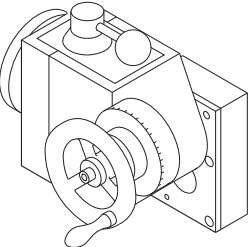
	NO.	DESCRIPTION
	<p>27218 27219 27220</p>	<p>(A) Main bed assembly Main bed has a 8" (203.2 mm) slide and 12" (304.8 mm) wide mounting flange. Flush-mount leadscrew bearings enable the machine to fit into areas as small as the length of the bed (plus the length of one feed mechanism). Assembly features a full-length leadscrew and anti-friction, high lubricity polymer on the ways.</p> <p>48" (1219.2 mm) travel main bed assembly 72" (1828.8 mm) travel main bed assembly 96" (2438.4 mm) travel main bed assembly</p>
	<p>22643</p>	<p>(B) 14" (355.6 mm) travel ram and cross slide assembly The ram and cross slide assembly feed the milling head across the main bed. Because the ram and main bed saddle have the same bolt hole pattern, the ram can be offset in 3.38" (85.85 mm) increments and/or positioned 90° around the saddle. The cross slide features dovetail ways and a full-length leadscrew.</p>
	<p>20888</p>	<p>(C) 6" (152.4 mm) travel vertical slide assembly The vertical slide assembly mounts to the ram and cross slide saddle to provide vertical movement for the milling head. Because the cross slide saddle and the vertical slide have the same bolt hole pattern, the vertical slide can be offset and/or positioned 90° around the saddle. The vertical slide features dovetail ways, a full-length leadscrew, and handwheel.</p>
	<p>20808 23650</p>	<p>(D) Manual feed assembly Handwheel assembly fits into either end of the leadscrew. Dial is graduated in .010" increments. One full turn of the dial equals .200" (5.08 mm). Though the machine can use more than one type of feed, each axis must have its own feed assembly. (The Z-axis includes its own handwheel.)</p> <p>Manual feed assembly - bed assembly (X-axis) Manual feed assembly - ram assembly (Y-axis)</p>
 <p>Drawings may not represent actual product.</p>	<p>21786 21509 22747 21512</p>	<p>(D) Standard electric feed assembly 1/8 hp (.09 kW) electric feed assembly attaches directly to either end of the main bed or ram leadscrews and provides 2:1 reduction feed. Unit has three mounting positions to clear obstructions. Feed speed and direction controls are on the feed unit. Dial is graduated in .001" increments. One full turn equals .100" (2.54 mm). Feed speed is up to 10" (254 mm) per minute. Includes switches (not shown). Recommended for horizontal applications only.</p> <p>Electric feed assy, 48" (1219.2 mm) travel main bed Electric feed assy, 72" (1828.8 mm) travel main bed Electric feed assy, 96" (2438.4 mm) travel main bed Electric feed assy, ram and cross slide</p>

PM5000 Components

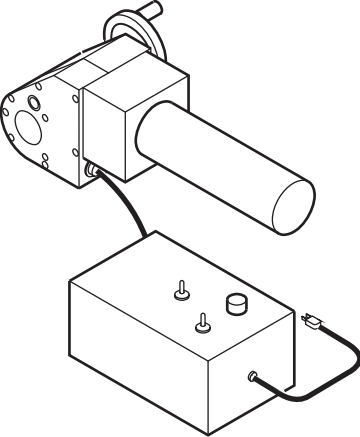
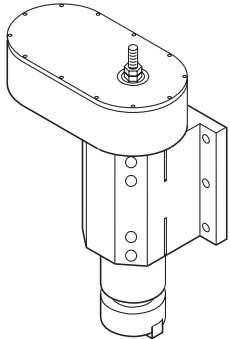
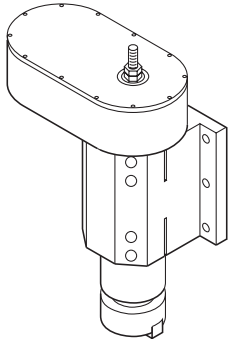
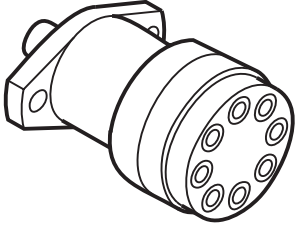
	NO.	DESCRIPTION																											
	<p></p> <p>29619</p> <p>29621</p> <p>29615</p> <p>29617</p> <p>30545</p> <p>30464</p>	<p>(D) Heavy-duty electric feed assembly with local control 1/8 hp (.09 kW) feed assembly attaches directly to either end of the base or ram leadscrews and provides 2:1 reduction feed. Unit has three mounting positions to clear obstructions. Dial is graduated in .001" increments. One full turn equals .100" (2.54 mm). Electric power feed speed is up to 24" (609.6 mm) per min. Assembly includes limit switches (not shown). Recommended for vertical and overhead applications.</p> <p>Heavy-duty electric feed assembly with local control, 48" (1219.2 mm) main bed</p> <p>Heavy-duty electric feed assembly with local control, 72" (1828.8 mm) main bed</p> <p>Heavy-duty electric feed assembly with local control, 96" (2438.4 mm) main bed</p> <p>Heavy-duty electric feed assembly with local control, ram and cross slide</p> <p>Heavy-duty electric feed assembly with local control, cross feed</p> <p>Heavy-duty local feed controller</p>																											
	<p>20997</p>	<p>(E) Tool Kit Complete set of tools, including instruction manual and hex wrenches.</p>																											
	<p>20667</p>	<p>(F) #40 Milling Head Assembly The hydraulically powered milling head mounts to the vertical slide assembly. The milling head can be positioned in 90° increments around the saddle. The compact aluminum gear box, with belt drive and a 1:1 drive ratio, can be rotated up to 180° around the end of the vertical slide to fit in tight places. A draw bolt and drive lugs hold the milling cutter securely in the spindle.</p>																											
 <p>Drawings may not represent actual product.</p>	<p>20684</p> <p>21530</p> <p>20231</p> <p>25492</p>	<p>(G) Hydraulic Drive Motors Reversible motors with SAE 2-bolt mounting flange to mount to the milling head gear box. Motor ports are 7/8-14 SAE O-ring type. Fittings are included with the hydraulic power unit. Power unit specifications: 5 hp; 6 gpm (22.7 L/min) 1200 psi (8268 kPa)* *For 50 Hz operation, torque remains constant and rpm decreases by 16%.</p> <p>Motor, hydraulic:</p> <table border="0"> <tr> <td>displacement</td> <td>3.6 in³</td> <td>59.0 cm³</td> </tr> <tr> <td>motor rpm</td> <td>363</td> <td></td> </tr> <tr> <td>motor torque</td> <td>563 in-lbs</td> <td>64 N•m</td> </tr> </table> <p>Motor, hydraulic:</p> <table border="0"> <tr> <td>displacement</td> <td>5.9 in³</td> <td>96.8 cm³</td> </tr> <tr> <td>motor rpm</td> <td>221</td> <td></td> </tr> <tr> <td>motor torque</td> <td>955 in-lb</td> <td>108 N•m</td> </tr> </table> <p>Motor, hydraulic:</p> <table border="0"> <tr> <td>displacement</td> <td>7.3 in³</td> <td>119.7 cm³</td> </tr> <tr> <td>motor rpm</td> <td>177</td> <td></td> </tr> <tr> <td>motor torque</td> <td>1209 in-lbs</td> <td>137 N•m</td> </tr> </table> <p>Hydraulic motor fitting kit - 3/8" fittings (not shown) Fitting kit includes fittings needed to connect motors listed above to power unit hoses with 3/8" female quick disconnect fittings. These fitting kits are included with every Climax hydraulic power unit.</p>	displacement	3.6 in ³	59.0 cm ³	motor rpm	363		motor torque	563 in-lbs	64 N•m	displacement	5.9 in ³	96.8 cm ³	motor rpm	221		motor torque	955 in-lb	108 N•m	displacement	7.3 in ³	119.7 cm ³	motor rpm	177		motor torque	1209 in-lbs	137 N•m
displacement	3.6 in ³	59.0 cm ³																											
motor rpm	363																												
motor torque	563 in-lbs	64 N•m																											
displacement	5.9 in ³	96.8 cm ³																											
motor rpm	221																												
motor torque	955 in-lb	108 N•m																											
displacement	7.3 in ³	119.7 cm ³																											
motor rpm	177																												
motor torque	1209 in-lbs	137 N•m																											

PM5000 Components

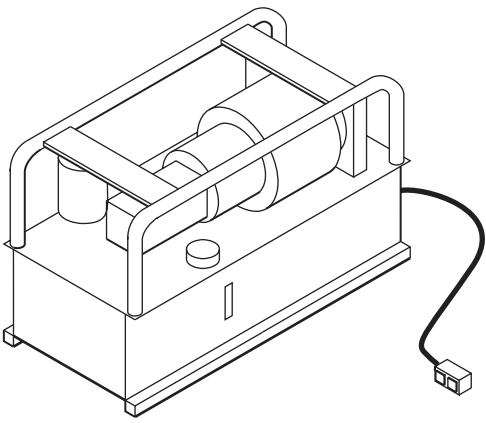
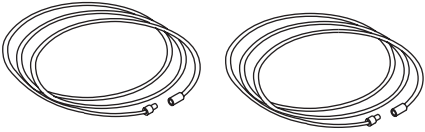
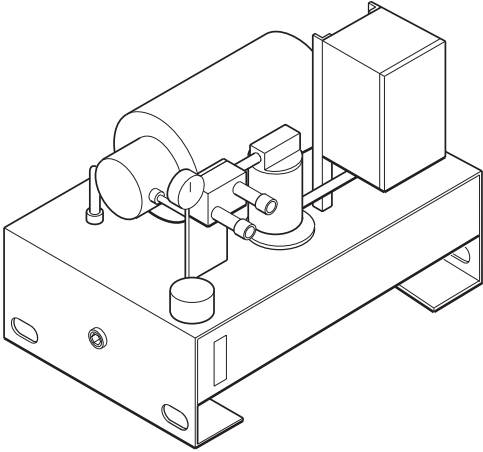
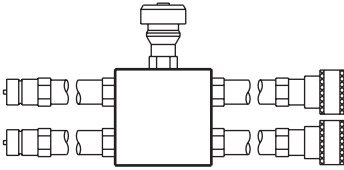
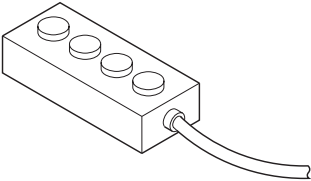
	NO.	DESCRIPTION
  <p data-bbox="232 905 602 961">Drawings may not represent actual product.</p> 	<p data-bbox="857 275 1222 296">(H) 5 hp (3.73 kW) hydraulic power unit</p> <p data-bbox="857 300 1398 443">Variable displacement piston pump power unit comes complete with a 5 gallon (19 liter) reservoir, START/STOP pendant, speed control, pressure gauge, 20 foot (6 meter) x 3/8" (9.5 mm) hydraulic hoses with quick disconnect fittings, and 7/8-14 SAE O-ring fittings for hydraulic motor. Order motor separately.</p> <p data-bbox="735 468 1304 489">25318 3-Phase electric powered hydraulic power unit</p> <p data-bbox="829 493 1377 514">230V, 60 Hz, 1800 rpm motor. Pumps 6 gpm (22.7 L/min).</p> <p data-bbox="735 518 1304 539">25319 3-Phase electric powered hydraulic power unit</p> <p data-bbox="829 543 1377 564">460V, 60 Hz, 1800 rpm motor. Pumps 6 gpm (22.7 L/min).</p> <p data-bbox="735 569 1304 590">25320 Single-phase electric powered hydraulic power unit</p> <p data-bbox="829 594 1377 615">550V, 50 Hz, 1400 rpm motor. Pumps 5 gpm (22.7 L/min).</p> <p data-bbox="735 619 1304 640">25321 3-Phase electric powered hydraulic power unit</p> <p data-bbox="829 644 1377 665">575V, 60 Hz, 1800 rpm motor. Pumps 6 gpm (19.0 L/min).</p> <p data-bbox="735 669 1304 690">25322 Single phase electric powered hydraulic power unit</p> <p data-bbox="829 695 1377 716">230V, 60 Hz, 1800 rpm motor. Pumps 6 gpm (19.0 L/min). Start up amperage: 54 amps.</p> <p data-bbox="735 720 1304 741">25323 Single phase electric powered hydraulic power unit</p> <p data-bbox="829 745 1377 766">220V, 50 Hz, 1400 rpm motor. Pumps 5 gpm (19.0 L/min). Start up amperage: 57 amps.</p> <p data-bbox="735 791 1304 812">24592 3-Phase electric powered hydraulic power unit</p> <p data-bbox="829 816 1377 837">440V, 50 Hz, 1400 rpm motor. Pumps 5 gpm (19.0 L/min).</p> <p data-bbox="735 842 1304 863">24593 3-Phase electric powered hydraulic power unit</p> <p data-bbox="829 867 1377 888">220V, 50 Hz, 1400 rpm motor. Pumps 5 gpm (19.0 L/min).</p> <p data-bbox="735 892 1304 913">24594 3-Phase electric powered hydraulic power unit</p> <p data-bbox="829 917 1377 938">380V, 50 Hz, 1400 rpm motor. Pumps 5 gpm (19.0 L/min).</p> <p data-bbox="735 942 1304 963">24595 3-Phase electric powered hydraulic power unit</p> <p data-bbox="829 968 1377 989">200V, 50 Hz, 1400 rpm motor. Pumps 5 gpm (19.0 L/min).</p> <p data-bbox="857 1014 1304 1035">(H) 5 hp (3.73 kW) economy hydraulic power unit</p> <p data-bbox="857 1039 1398 1203">Variable displacement piston pump power unit comes complete with starter/overload relay, oil cooler, return line oil filter, 10 gallon (38 liter) reservoir, control pendant with 20 foot (6 meter) cord, and a pair of 20 foot (6 meter) x 3/8" (9.5 mm) hydraulic hoses with quick disconnect fittings, and 7/8-14 SAE O-ring fittings for hydraulic motor. Order motor separately.</p> <p data-bbox="735 1228 1304 1249">31525 3-Phase electric powered hydraulic power unit</p> <p data-bbox="829 1253 1398 1274">230V, 60 Hz, 1725 rpm motor. Pumps 6.38 gpm (22.8 L/min).</p> <p data-bbox="735 1278 1304 1299">31526 3-Phase electric powered hydraulic power unit</p> <p data-bbox="829 1304 1398 1325">460V, 60 Hz, 1725 rpm motor. Pumps 6.38 gpm (22.8 L/min).</p> <p data-bbox="735 1329 1304 1350">31527 Single-phase electric powered hydraulic power unit</p> <p data-bbox="829 1354 1398 1375">230V, 60 Hz, 1725 rpm motor. Pumps 6.38 gpm (22.8 L/min).</p> <p data-bbox="735 1379 1304 1400">31528 3-Phase electric powered hydraulic power unit</p> <p data-bbox="829 1404 1398 1425">380V, 50 Hz, 1425 rpm motor. Pumps 5.38 gpm (20.4 L/min).</p> <p data-bbox="735 1430 1304 1451">31529 3-Phase electric powered hydraulic power unit</p> <p data-bbox="829 1455 1398 1476">440V, 50 Hz, 1425 rpm motor. Pumps 5.38 gpm (20.4 L/min).</p> <p data-bbox="735 1480 1304 1501">31530 3-Phase electric powered hydraulic power unit</p> <p data-bbox="829 1505 1398 1526">550V, 50 Hz, 1425 rpm motor. Pumps 5.38 gpm (20.4 L/min).</p>	<p data-bbox="829 1560 1068 1581">31531 Adjustable flow control</p> <p data-bbox="829 1585 1122 1606">For 5 hp hydraulic power units.</p> <p data-bbox="735 1631 1206 1652">25882 Replacement hydraulic filter element</p> <p data-bbox="829 1656 1122 1677">For 5 hp hydraulic power units.</p> <p data-bbox="735 1703 1162 1724">14420 Hydraulic fluid - 1 gallon (3.79 L)</p> <p data-bbox="829 1728 1263 1749">Mobil DTE-24 Anti-Wear brand hydraulic fluid.</p>
		
	<p data-bbox="735 1797 1333 1854">-1 Remote pendant (spindle RPM control only), 5 hp (3.73 kW) electric hydraulic power unit</p>	<p data-bbox="829 1858 1398 1938">Multifunction pendant replaces standard pendant. Functions include: Emergency Stop, Power Unit On, Jog/Run selector, Slow/Fast Motor Speed Control. To order add "-1" to the desired power unit number. Example: "25318-1."</p> <p data-bbox="829 1942 1349 1984">Order pendant when ordering power unit or return power unit to Climax for upgrade.</p>

PM5000 Components

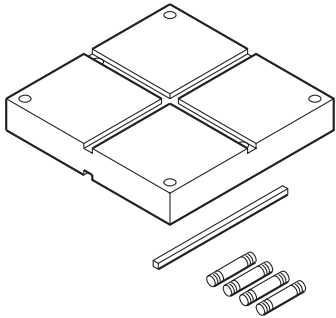
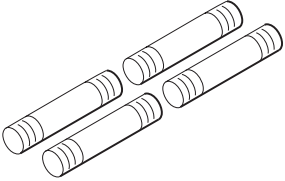
	NO.	DESCRIPTION
	<p>25021 21593 25022 25023 25024 25025</p>	<p>(I) Riser assembly Riser assembly raises the milling head up from the main bed. Assembly includes riser, studs and nuts, and key. For overhead milling, riser(s) totaling a minimum of 3" (76.2 mm) are required. Risers totaling 5" (127 mm) or more are recommended.</p> <p>1" (25.4 mm) Riser assembly 2" (50.8 mm) Riser assembly 3" (76.2 mm) Riser assembly 4" (101.6 mm) Riser assembly 5" (127.0 mm) Riser assembly 6" (152.4 mm) Riser assembly</p>
 <p>Drawings may not represent actual product.</p>	<p>25030 21595 25031 25032 25033 25034 25040</p>	<p>Optional riser studs Order optional riser studs when using a combination of risers to raise the milling head up from the main bed. Four studs required.</p> <p>Stud - 1" (25.4 mm) total riser height Stud - 2" (50.8 mm) total riser height Stud - 3" (76.2 mm) total riser height Stud - 4" (101.6 mm) total riser height Stud - 5" (127.0 mm) total riser height Stud - 6" (152.4 mm) total riser height Stud - 7" (177.8 mm) total riser height</p>



CLIMAX

Portable Machine Tools, Inc.
2712 E. Second St., P.O. Box 1210
Newberg, OR 97132-8210 U.S.A.
Worldwide Tel. 503/538-2185
FAX 503/538-7600

Call Toll Free 800/333-8311

Visit our web site at www.cpmt.com